

2 COMPAS À GAZ D'ASSISTANCE



2 VERROUS AUTOMATIQUES



OPTION POIGNÉE

DONNÉES TECHNIQUES

Code article	Désignation	Longueur (mm)	Hauteur (mm)	Poids (kg)
T7160300	Profil hexagonal acier + supports	2 320	126	50
T7160530	Platines DAF et Iveco	395	260	20
T7160540	Platines MAN, Daimler Truck, Scania, Renault et Volvo Trucks			
T7161425	Bras courts (paire)		680	29
T7161430	Bras longs (paire)		830	34
T7161482	Compas à gaz 700 N			0,5
T7161486	Compas à gaz 1 100 N			
T7160350	Poignée			1
T5205224	Kit visserie M14			5,5
T5205226	Kit visserie M16			7

HOMOLOGUÉ
R58.03

MADE IN
TRAXION

+
LÉGER
DE CO₂

EN DÉTAIL



- BAE 25 % plus légères que les solutions actuellement sur le marché
- Deux longueurs de bras pour s'adapter à toutes les configurations de véhicules (recoupables)
- Profil hexagonal Traxion
- 2 platines de liaison au châssis tous constructeurs
Fixation par 4 vis
- Descente et relevage assistés par deux compas à gaz protégés des chocs
- Fermeture par verrous automatiques à deux positions : abaissée / relevée
- Finition cataphorèse
- Compatible traverses surbaissées Traxion
- En option : kits visserie M14 et M16 pour liaison au châssis

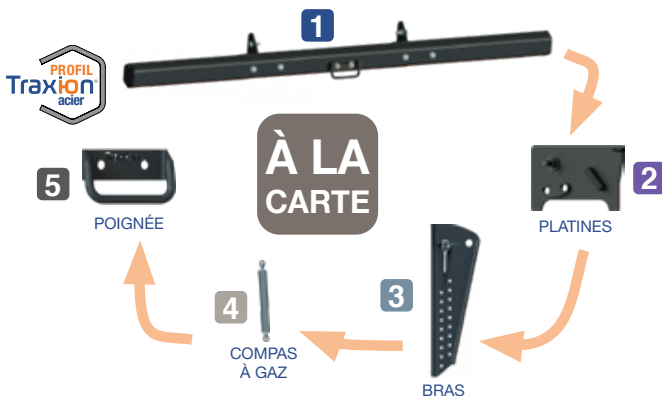

Bras longs et courts (compas 1 100 N)
Bras courts raccourcis (compas 700 N)

Formulaire de commande sur www.traxion.fr

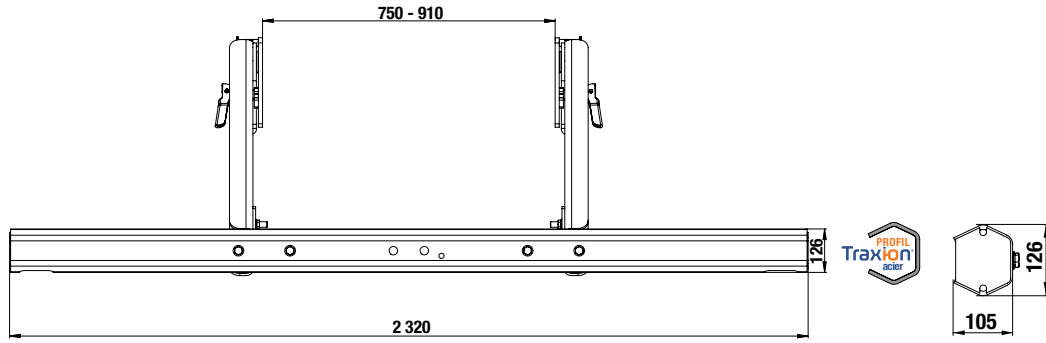

BRAS 680 mm

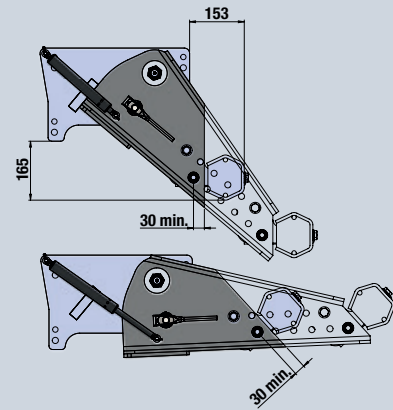
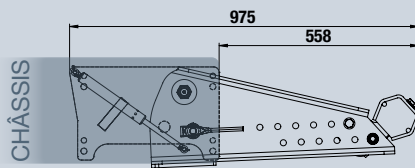
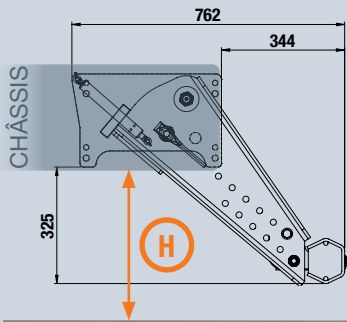

BRAS 830 mm

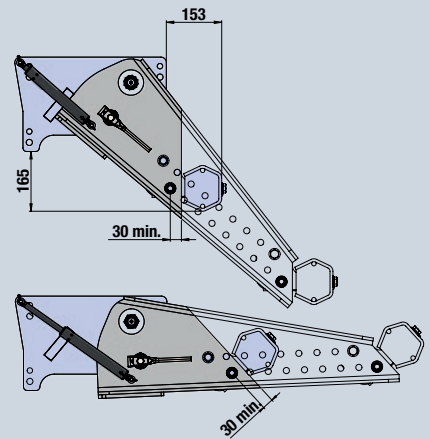
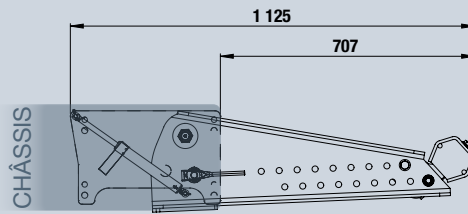
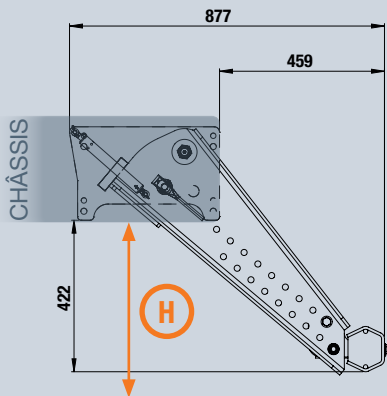

COMMENT CHOISIR LA LONGUEUR DES BRAS ?

Suspensions	Bras 680 mm	Bras 830 mm
	$H \leq 776 \text{ mm}$	$H \leq 872 \text{ mm}$
	$H \leq 826 \text{ mm}$	$H \leq 922 \text{ mm}$

Les bras peuvent être raccourcis tous les 50 mm jusqu'à minimum 30 mm du dernier trou

PLATINES

DAF
IVECO

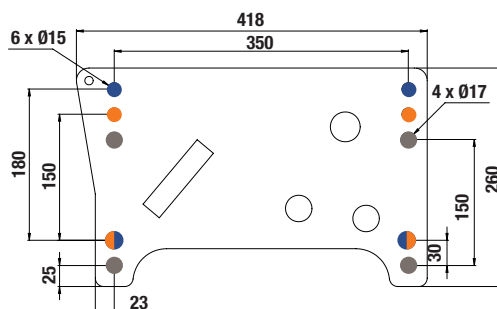
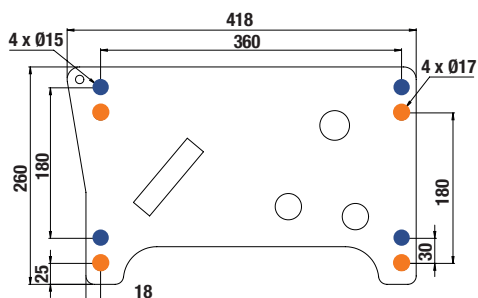

MAN
DAIMLER TRUCK
RENAULT TRUCKS
SCANIA
VOLVO TRUCKS