

TRAVERSE | ENTRETOISES

POIDS LOURDS | POUR TFC-MD / HD / UHD

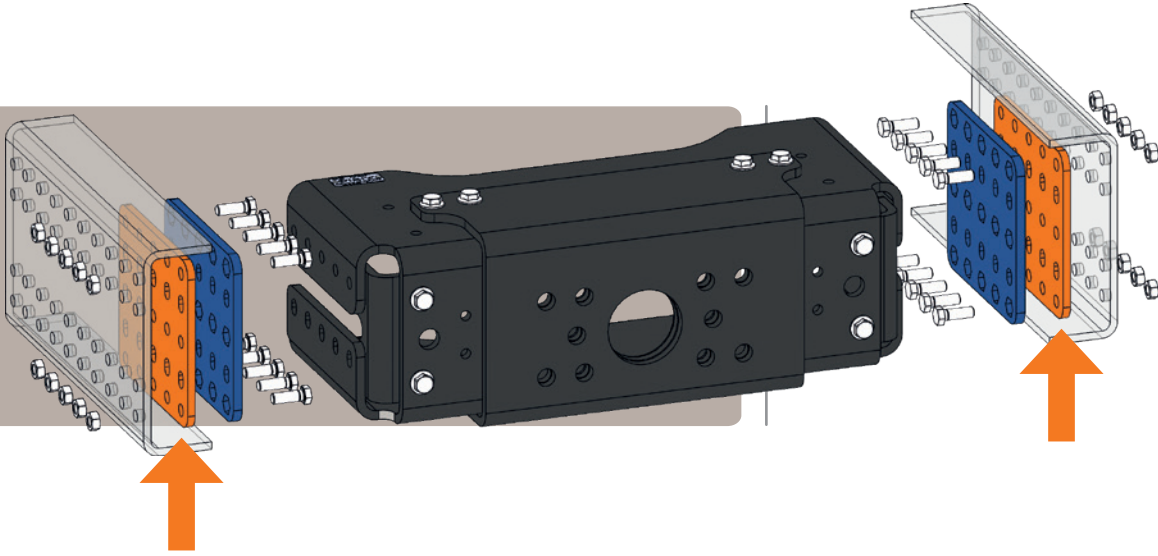

DONNÉES TECHNIQUES

Ép. (mm)	DAF	IVECO	MAN TRUCK & BUS	MERCEDES-BENZ	RENAULT TRUCKS & VOLVO TRUCKS	SCANIA
5	T5800605 ⁽¹⁾	T5800105	T5800205	T5800705	T5800405 ⁽¹⁾	T5800505
6	T5800606 ⁽¹⁾	T5800106	T5800206	T5800706	T5800406	T5800506
8	T5800608	T5800108	T5800208	T5800708	T5800408	T5800508 ⁽¹⁾

⁽¹⁾ réf. tenue sur stock - Pour toute autre épaisseur, nous consulter

HOMOLOGUÉ
R55

MADE IN TRAXION

EN DÉTAIL

- A monter entre le châssis (non doublé) et les traverses gammes moyenne et lourde
- Finition cataphorèse noire

SCHÉMAS TECHNIQUES

